

LASER[®]

Engine Timing Locking Tool Set

Camshaft | Crankshaft | Flywheel

Citroen | Fiat | Ford | Opel | Peugeot | Renault | Rover | Vauxhall | Volkswagen



Warning

It is always recommended to refer to the vehicle manufacturers workshop manual for specific procedures and technical data when using these tools.

Incorrect or out of phase engine timing can result in damage to valves. It is always recommended to turn the engine slowly by hand and to recheck the camshaft and crankshaft timing positions.

Our application directory should be used as a guide only and The Tool Connection cannot be held responsible for any damage caused to your engine by using these tools.

Safety

Care should be taken when working on the engine and full protection should be worn. The Tool Connection cannot be held responsible for any personal injury caused when using these tools.

Replacement parts can be ordered direct from The Tool Connection and not through your distributor.

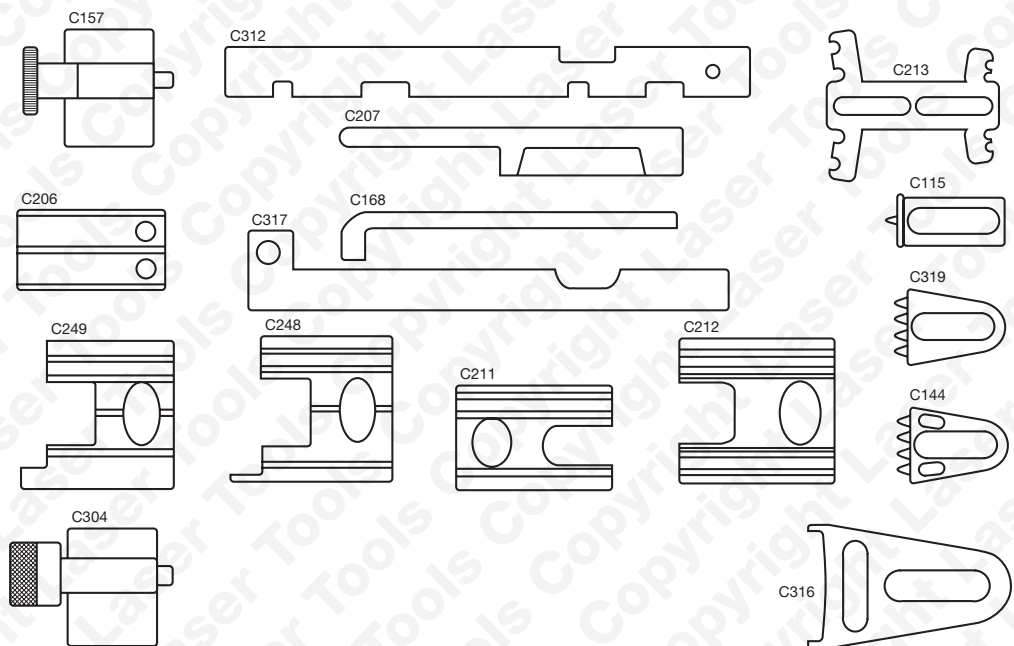

Component Code	Description	OEM Code	Manufacturer	Model	Engine
C211	Twin Camshaft Locking Tool	KM852	Vauxhall/Opel	Astra-G 1.4/1.6/1.8 16v Corsa-C 1.4/1.8 16v Vectra-B/C 1.4/1.6/1.8 16v Zafira 1.6/1.8 16v	X14XE, X16XEL, X16SEJ, X18E1, Y16XE, Z14XE, Z16XE, Z16YNG, Z18XE, Z18XEL
C213	Flywheel Locking Tool	KM517B	Vauxhall/Opel	Astra-F 1.7 D/TD, Astravan 1.7 D/TD, Cavalier 1.7D, Vectra-A 1.7D	17DR X17DTL
C115	Flywheel Locking Tool	0134AF 0134Q 0188F 9044-T	Peugeot/Citroen	1.8/2.0 16v 1.9 2.1 HDi	XU, XUD, DW
C304	Crankshaft Setting Tool	T10100	Volkswagen	Golf/Golf Plus/Jetta/Touran 2.0 TDi PD DOHC	AZV BKD Non bored engine
C144	Flywheel Locking Tool	1 860 161 000	Fiat	Ulysse 1.8/2.0/Turbo Ducato 2.0	LFW, RFU, RGX, RFW
C319	Flywheel Locking Tool	MOT 582-1	Renault	Clio, Twingo, Kangoo, D7F, Megane/Scenic, Laguna, Express/Extra	K7M, K4J, K4M, F4P, F4K F8Q, F9Q
C316	Flywheel Locking Tool	MOT 1316	Renault	Laguna 2.2 D/TD, Safrane 2.2 D/TD, Espace 2.2 D/TD	G8T
C317	Camshaft Setting Bar	303-692 21-246	Ford	Puma 1.7	MHA, MHB
C168	Flywheel Locking Tool	KM911	Vauxhall/Opel	Astra-G 1.4/1.6/1.8 16v Corsa-C 1.4/1.8 16v Vectra-B 1.4/1.8 16v Zafira 1.6/1.8 16v Astra-G 1.4/1.6/1.8 16v Vivaro 1.9 DTi, Meriva 1.6	Z16LET Z16XEP F9Q 76 F9Q 760 X16SZR, Z16SE
C207	Camshaft Locking Tool	KM8070	Vauxhall/Opel	Midi	4FCi-T 4FDi 4GDi
C157	Crankshaft Locking Tool	T10050/ 310-085	Volkswagen	Beetle/Bora/Golf 1.9 TDi PD Lupo 1.4/1.2 TDi PD/3L 1.2 Passat 1/9 TDi PD Polo 1.4/1.9 TDi PD Sharan 1.0 TDi PD Golf/Golf Plus/Jetta/Touran 2.0 TDi PD DOHC	AVQ, BJB, BKC, BRU AJM, AMF, ANU, ARL, ASZ, ATD, AUY, AXR, BAY, ANY, AYZ (AZV, BKD Non bored engine)
C312	Camshaft Setting Bar	303-376B	Ford	Focus 1.6, Focus C-Max 1.6	HWDA, HWDB

Component Code	Description	OEM Code	Manufacturer	Model	Engine
C212	Twin Camshaft Locking Tool	KM853	Vauxhall/Opel	Astra-G 2.0/2.2 Turbo/16v Frontera-B/Omega-B/Sintra-A 2.2 16v, Vectra 1.8/2.0 16v Zafira 2.0 Turbo	X22SE, X22XE, Y22SE, Y22XE, Z22XE, Z20LET X18XE X20SEL, X20XEV
C248	Camshaft Locking Tool RH	KM800-1	Vauxhall/Opel Saab	Calibra/Cavalier V6/V6i 2.5 Omega-B V6 2.5/2.6/3.0/3.2 Sintra 3.0 V6, Vectra-A-B 2.5/2.6 V6/V6i 900,9000,9-5 2.5,3.0 V6	X25XE, X30XE, Y26SE, Y32SE
C249	Camshaft Locking Tool LH	KM800-2	Vauxhall/Opel Saab	Calibra/Cavalier V6/V6i 2.5 Omega-B V6 2.5/2.6/3.0/3.2 Sintra 3.0 V6, Vectra-A-B 2.5/2.6 V6/V6i 900,9000,9-5 2.5,3.0 V6	X25XE, X30XE, Y26SE, Y32SE
C206	Camshaft Locking Tool	18G 1570	Rover	200 2.0/Turbo/1.6/1.8/1.8 V/ Coupe/Cabrio 1.6 DOHC/1.8/2.0 25 1.1/1.6/1.8/1.8 WC/2.0 TurboD 400 1.6/2.0D Turbo/2.0/1.6 DOHC/1.8D	K16