

**Care Point:**

The threaded portion of the central force screw must be lightly lubricated with a high quality molybdenum disulphide grease or machine oil.

**Precautions**

- If vehicle is raised, ensure it is adequately supported with axle stands, ramps, etc, as appropriate.
- Wear suitable eye protection.
- Follow manufacturer's instructions for pad and caliper removal.
- Take care not to strain the hydraulic flexible hose and do not support the weight of the caliper on the flexible hose.
- Maintain the tools in good and clean condition and always return to case for safekeeping.
- **DO NOT** use tool if damaged or worn.
- **DO NOT USE AIR TOOLS WITH THIS PRODUCT.**



**Safety First. Be Protected.**

**Guarantee**

This item contains consumable elements and are **NOT** covered by the Tool Connection Guarantee. For spares contact our service department director: +44 (0) 1926 818186.



Distributed by The Tool Connection Ltd

Kington Road, Southam, Warwickshire CV47 0DR  
T +44 (0) 1926 815000 F +44 (0) 1926 815888  
info@toolconnection.co.uk www.toolconnection.co.uk



# LASER<sup>®</sup>

## Brake Rewind Tool Adjustable

### Instructions

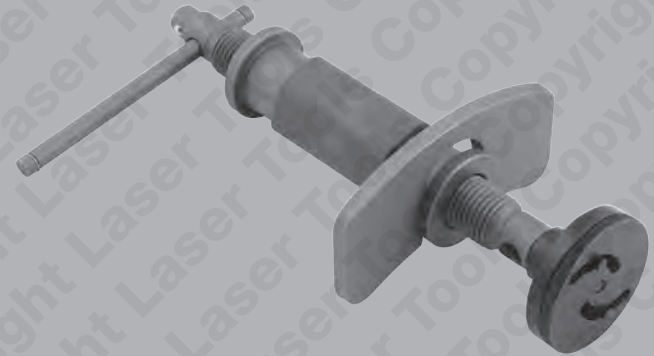

**A particularly versatile brake rewind tool that features:**

- An adjustable drive key adaptor that will fit many vehicle applications.
- Right-hand and left-hand force screws in the one tool.

## Instructions

### Ensure the handbrake is OFF.

Refer to the manufacturer's instructions on how to remove the brake pads and caliper. Take care not to strain the hydraulic flexible hose. Ascertain from the manufacturer's instructions whether the caliper piston has a right or left-hand thread when winding back.

### Adjusting the drive key adaptor pins:

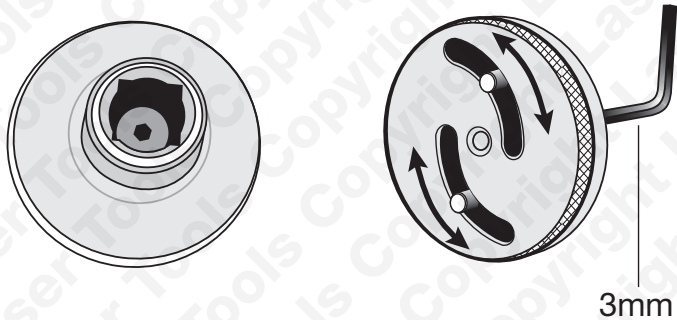

Refer to diagram. The adjustable drive key adaptor locking screw is accessed from the rear 3/8" drive socket. Loosen the screw with a 3mm hex key and then adjust the pins to fit the corresponding holes or sockets in the caliper piston.

The pins can be adjusted to any position between 15mm - 35mm (distance between pin centres). Lock the pins in position by turning the locking screw clockwise - do not overtighten.

**The torque required to turn the piston back should be easily obtainable with use of the T-bar provided. If excessive torque is required it is possible the pins on the adaptor will fail. This is an indication that the brake caliper requires attention and should be properly overhauled. Whilst the pins are made from hardened steel, their size dictates the torque they can withstand, as such, the drive pins should be considered a consumable item. The 5668 adjustable adaptor is not suitable for use on any sort of impact driver.**

Spare pins are available - Part No. 5789.

## Instructions

### Using the brake rewind tool:

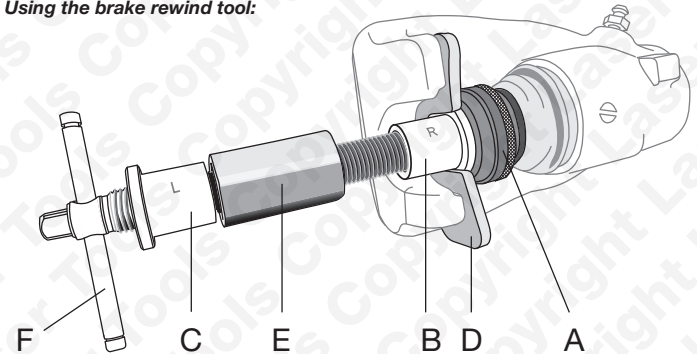

A	Adjustable drive key adaptor
B	Collar (Right-hand thread)
C	Collar (Left-hand thread)
D	Reaction plate
E	Centre grip
F	T-bar

- Adjust the drive key adaptor (A) as detailed above.
- Fit the adaptor to the correct end of the rewind tool (for either right-hand or left-hand threaded caliper pistons).
- Refer to diagram: assemble to rewind tool to the caliper with the threaded collar (B or C) fitting into the recess in the reaction plate (D). Wind the opposite threaded collar away from the centre grip (E).
- Before forcing the piston back it is considered best practice to open the caliper bleed nipple and fit a bleed bottle (recommend Laser Part No. 2906), so that when the piston is pushed back the old fluid in the caliper is expelled from the system and not forced back up to the reservoir.
- Put pressure on the T-bar (F) to force the drive key adaptor against the piston as you start to wind in either a clockwise or anticlockwise direction.
- Wind the piston in just enough to give adequate clearance for fitting the new brake pads. Then wind the T-bar back off enough to release the rewind tool from the caliper.
- When finished, check the brake fluid reservoir level and replace with new brake fluid as necessary.