

Precautions

- Take great care when working with hot, pressurised cooling systems. High risk of scalding. Always wear hand and eye protection.
- Refer to manufacturer's service instructions for correct procedures and data.
- Ensure radiator/cooling system is cool before removing cap.
- Always refer to instructions before use.
- Do not pump pressure above 15-20psi.
- Ensure the gauge is reading zero (to indicate no pressure) before disconnecting.
- Observe standard workshop safety procedures when using the tester.



Safety First. Be Protected.

30 March 2017 10:52 AM

Guarantee

If this product fails through faulty materials or workmanship, contact our service department direct on: **+44 (0) 1926 818186**. Normal wear and tear are excluded as are consumable items and abuse.



Distributed by The Tool Connection Ltd

Kineton Road, Southam, Warwickshire CV47 0DR
T +44 (0) 1926 815000 F +44 (0) 1926 815888
info@toolconnection.co.uk www.toolconnection.co.uk



www.lasertools.co.uk

5614

LASER[®]

Cooling System Pressure Test Kit Universal - 25pc

Instructions



- A comprehensive cooling system pressure testing kit for universal use.
- 25 pieces including 17 individually sized threaded adaptors, pressure testing pump with gauge, 2 connectors for pressure testing bayonet style caps and an adaptor cap wrench.
- Thermometer included for temperature measurement of radiator core, expansion tanks etc.
- Also checks the leakage on original radiator cap.
- Updated applications included (2017) - see website for full details.

www.lasertools.co.uk

Cooling System Pressure Tester

High quality cooling system pressure tester with a comprehensive set of adaptor caps which fit a wide range of vehicles. Supplied with a thermometer to aid diagnostics and ensure system is cool before removing cap.

Locates system leaks from header/expansion tanks and fittings, head gasket, radiator core, heater matrix, water pump, hoses, pipes, etc.

Adaptors have quick-release couplings and pump is fitted with large, easy to read dial clearly marked in both psi and bar.

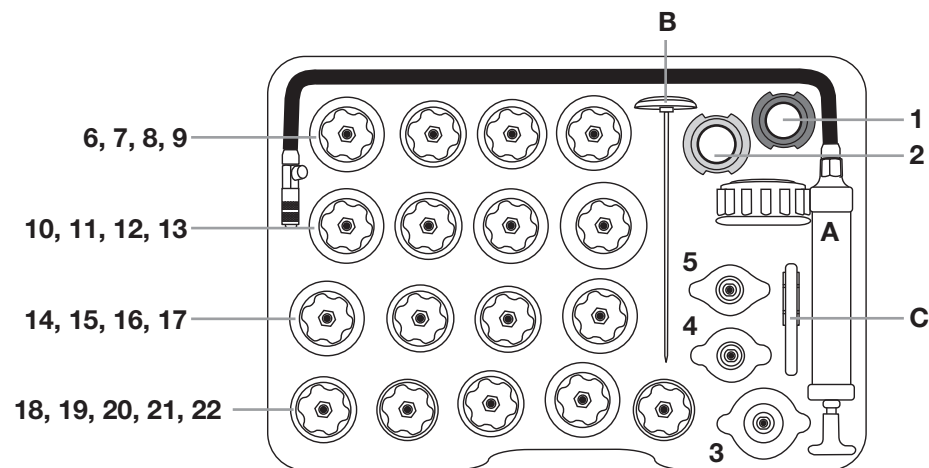

Code	Description
A	Pressure testing pump with gauge
B	Thermometer
C	Adaptor spanner
1	Radiator cap test connector R123/R125 (blue)
2	Radiator cap test connector R123/R124 (black)
3 - 22	Radiator/Expansion tank adaptor caps (refer to application list)

Opel/Vauxhall	Agila, Astra F/G/H, Corsa A/B/C, Meriva, Zafira	upto 2005	4, 12
Opel/Vauxhall	Astra H/J, Corsa, Vectra, Zafira	2005 to 2006	21
Opel/Vauxhall	Movano, Vivaro	1998 on	7
Opel/Vauxhall	Adam, Astra J/K, Corsa D/E, Insignia, Meriva, Moka, Zafira C	2006 on	17 + see note*
Peugeot	106, 1007, 108, 2008, 206, 207, 208, 3008, 307, 308, 406, 407, 4007	2000 on	7
Peugeot	508, 607, 807, 1007, 2008, RCZ	2000 on	7
Peugeot	Bipper, Boxer, Expert, Partner	2000 on	7
Peugeot	106, 205, 306, Boxer,	up to 2000	3
Porsche	911	1999 on	6
Porsche	Boxter	1997 on	6
Porsche	Cayenne	2010 on	9
Porsche	Cayman, Macan, Panamera	All Years	9
Renault	All models	1998 on	7
Saab	900	1994 to 1998	6
Saab	9,3	1998 to 2002	6, 20
Saab	9,5	1997 to 2009	6, 20
Saab	9,5	2010 on	17 + see note*
Seat	Arosa, Cordoba, Cordosa, Ibiza, Inca (with internal thread on expansion bottle)	upto 2004	8
Seat	Altea, Cordoba, Ibiza, Leon, Toledo, Exeo,	2006 on	9
Seat	Alhambra	1996 to 2010	18
Skoda	All Models	1996 on	9
Subaru	All models	1984-	4, 5
Suzuki	All Models	1998 on	4, 5
Toyota	4 Runner	1986 on	4, 5
Toyota	Auris, Avensis, Camry, Carina, Corolla, Yaris, Hiace,	1986 on	4, 5, 19
Toyota	Avensis, Celica, Corolla, MR2 III, RAV 4 II/III/IV, Yaris, Prius	2001 on	19
Volkswagen	Beetle	1998 on	9
Volkswagen	Beetle (with internal thread on filler neck of expansion tank)	1990 to 1997	8
Volkswagen	Golf All	1983 on	8, 9, 11
Volkswagen	Jetta, Caddy II/IV, Bora, CC, Eos, Fox, Lupo	2000 on	9
Volkswagen	Passat, Pheaton, Polo, Scirocco, Sharan, Tiguan, Transporter, UP	1998 on	9
Volkswagen	Passat, Vento, Sharan, Golf, Jetta (with internal thread on expansion tank)	1990 on	8
Volkswagen	T4 (with internal thread on expansion tank)	1990 to 1998	8
Volkswagen	Sharan	1996 to 2010	18
Volvo	440, 460, 480, 740, 760, 780, 850, 940, 960, S70, S90, V90	1988 on	7
Volvo	C70, S40, S60, S80, V40, V70, XC70, XC90	1995 on	7, 15
Volvo	V50, V60, XC60	2004 on	15

Special Note: * = for vehicle using adaptor 17 +* move upper small diameter seal to middle groove.

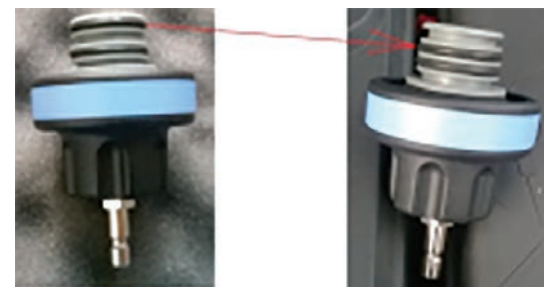

Ford	Galaxy	1995 to 2006	18
Ford	Mondeo	2000 on	15
Honda	All Models	All Years	4, 5
Hyundai	All models	All Years	4, 5
Isuzu	All models	All Years	4, 5
Jaguar	S-Type	2000 on	6
Jaguar	X Type	2002 on	6
Jaguar	XF (X250)	2008 on	6
Jaguar	XF (X260)	2015 on	6
Jaguar	XE (X760)	2015 on	6
Jaguar	F-Pace (X761)	2016 on	6
Jaguar	F-Type (X152)	2013 on	6
Jaguar	XJ (X351)	2010 on	6
Jaguar	XK (X150)	2006 on	6
Jeep	Compass, Grand Cherokee, Patriot, Wrangler	1983 to 2010	3
Kia	All Models	All Years	4, 5
Land Rover	Defender (L316)	2015 on	16
Land Rover	Discovery	1989-04	6
Land Rover	Discovery 3, 4	2005 to 2014	6
Land Rover	Freelander	2003 on	21
Land Rover	Land Rover Freelander 2 (LF)	2006 to 2014	15
Land Rover	Range Rover	1998 to 1994	6
Land Rover	Range Rover (L322)	2002 on	6
Land Rover	Range Rover (L405)	2012 on	6
Land Rover	Discovery 4 (L319)	2009 on	6
Land Rover	Range Rover Sport (L320)	2005 on	6
Land Rover	Range Rover Sport (L494)	2013 on	6
Land Rover	Range Rover Discovery 5 (L462)	2017 on	6
Land Rover	Range Rover Evoque (L538)	2011 on	15
Land Rover	Discovery Sport (L550)	2015 on	15
Lexus	All Models	All Years	4, 19
Mazda	All models	1985 to 1998	4
Mazda	Mazda 2	2003 on	6
Mazda	Mazda 3, 5 CX3, CX5, MX5	1998 on	5
Mercedes-Benz	A Class, B Class, Vaneo	1997 to 2012	16
Mercedes-Benz	C Class	2001 on	13
Mercedes-Benz	E Class	1996 on	13
Mercedes-Benz	S Class	1994 on	13
Mercedes-Benz	Sprinter, Vaneo, Vito	All Years	3, 13, 16
Mini	Mini R50/R52/R53	2002 to 2006	7
Mini	Mini R55/R56/R57/R58/R59/R60/ R61/F57	2006 on	22
Mitsubishi	ASX, Carisma 1.5/1.6/1.8, Colt II/III/IV/VI	all years	5
Mitsubishi	FTO, Gallant, GTO, Lancer, Pjaero/Shogun, L 200, L 300	all years	5
Mitsubishi	Outlander PHEV (Engine cooling system)	2013 on	5
Mitsubishi	Outlander PHEV (Motor Control unit)	2013 on	7
Mitsubishi	Carisma 1.9D	1996 on	7
Mitsubishi	Lancer, L200, Galant, Mirage, Lancer, Pajero, Shogun	all years	4, 5
Mitsubishi	Outlander I/II	2003 on	5
Nissan	200SX, 350Z, 370Z, Almera, Blue Bird, Cube 1.4/1.6 16V, Micra	upto 2003	5
Nissan	Murano, Juke upto 2012, Sky Line, X trail upto 2013,	upto 2013	5
Nissan	Cube, Juke	2012 on	7
Nissan	Kubistar, Micra III, Interstar, Primastar	2003 on	7
Nissan	Note, Qashqai	2006 on	7
Nissan	NV200	2010 on	7

Instructions

1. Take great care when working with hot, pressurised cooling systems. High risk of scalding. Always wear hand and eye protection.
2. Ensure radiator/cooling system is cool before removing cap.
3. Remove the cap from the radiator, expansion or header tank and clean around cap area.
4. Refer to application list and choose the correct adaptor cap.
5. Fit the adaptor cap to the radiator, expansion or header tank and ensure that it is tightly sealed. Use adaptor spanner (C) to fully tighten (refer to diagram).

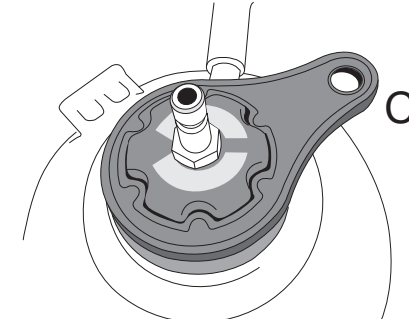

6. Connect the pump to the adaptor cap by means of the quick-release coupling.
7. Pump until pressure is approximately 10-15psi.
8. If the gauge pointer remains still for one minute this indicates that the cooling system is sealed and in good order. If the pointer falls, this indicates a leak resulting in loss of pressure.
9. If a leak is indicated, check the system and rectify as necessary.
10. If there is a pressure loss but no leak can be found, then check the condition of the head gasket and/or on some engine applications the inlet manifold gasket.
11. When repairs have been completed, retest the system.

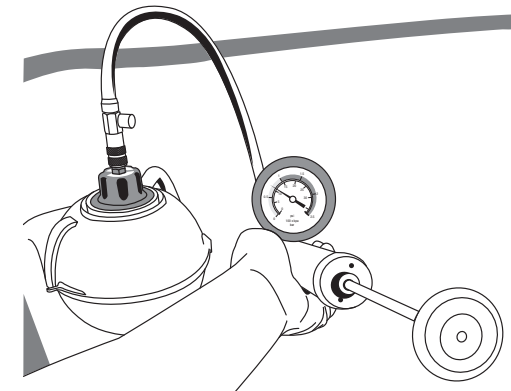

NOTE:

- To release pressure from the pump, press the release valve at the quick-release coupling. Ensure the gauge reads zero before disconnecting.
- Do not pump pressure above 15-20psi.

Pressure Cap Pressure Test

- Two test connectors are included in the kit (**1** and **2**), choose the correct one for the application.
- Fit the radiator/expansion tank cap to the smaller end of the test connector and fit the pressure adaptor cap (**3**) to the other end.
- Refer to the label on the radiator/expansion tank cap (or manufacturer's data) and apply pressure with the pump.
- Check for leaks.

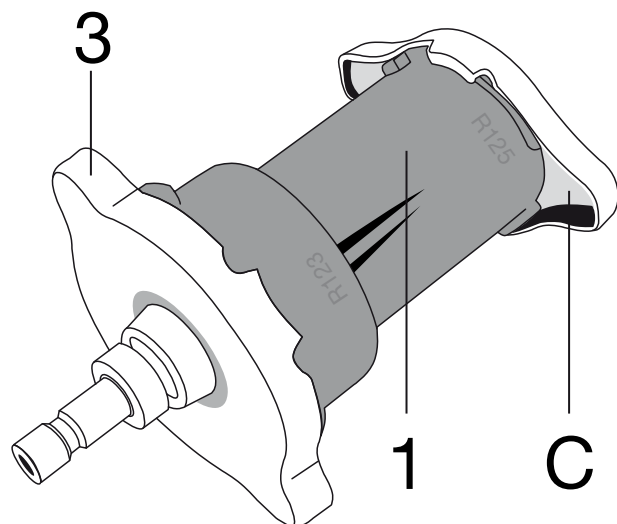

Code	Description
3	Radiator/Expansion tank adaptor cap
1	Radiator cap test connector
C	Vehicle cap to be tested

Applications

Make	Model	Year	Adaptor No
Alfa Romeo	145, 146, 164, 166, 33, GTV, Spider circa 1994 to 2005	1994 to 2005	7
Alfa Romeo	Spider, Brera, 159.	2005 on	21
Audi	A2, A3, A4, A6, A7, A8, Q3, Q5, Q7, TT from 1996	1996 on	9
Audi	A6, A8, Cabriolet	upto 2000	11
BMW	3 Series (E30, E36, E46)	1982 to 2005	10
BMW	5 Series (E60, E34, E39)	1991 to 2004	10
BMW	7 Series (E23, E32, E38, E65, E66, E67)	1977 to 2008	10
BMW	Z3 (E36), Z4 (E85), Z8 (E53)	1997 to 2008	10
BMW	Z4 E89,	2008 on	17
BMW	1 Series (E81, E87, F20, F21)	2004 on	17
BMW	2 Series (F21, F87, F23)	2013 on	17
BMW	3 Series (E90, E91, E92, E93, F30, F80, F31, F34)	2005 on	17
BMW	4 Series (F32, F82, F33, F83, F36)	2013 on	17
BMW	5 Series (F07, F10, F11, F18)	2009 on	17, 22
BMW	6 Series (E63, E64)	2003 on	17
BMW	6 Series (F12, F13, F06)	2011 on	22
BMW	7 Series (F01, F02, F03, F04, G11, G12)	2012 on	17, 22
BMW	X1 (E84)	2009 to 2015	17
BMW	X3 (F25)	2010 on	17
BMW	X4 (F26)	2014 on	17
BMW	X5 (E70, F15, F85)	2007 on	17, 22
BMW	X6 (E71, E72, F16, F86)	2008 on	17, 22
BMW	I3	2013 on	22
Chevrolet	Aveo	2006 on	6
Chevrolet	Epica	2005 on	6
Chevrolet	Kalos	2005 on	6
Chevrolet	Laceti	2005 on	6
Chevrolet	Matiz	2005 on	6
Chevrolet	Nubira	2005 on	6
Chevrolet	Spark (0.8Lt)	2005 on	6
Chevrolet	Aveo, Corvette, Cruze, Spark	2010 on	17 + see note*
Chrysler	Crossfire	2004 on	3
Chrysler	300c	2004 on	3
Chrysler	Voyager	1995 to 2008	3
Chrysler	PT Cruiser	2000 to 2010	3
Chrysler	Neon	2001 to 2006	3
Citroen	Berlingo, C-Elysee, C-Crosser, C1, C2, C3, C4, C5, C6, C8,	All Years	7
Citroen	Dispatch, Relay, Synergie, Xsara Picasso	All Years	7
Citroen	DS3, DS4, DS5, Nemo	2008 on	22
Citroen	Xantia, XM, BX	All Years	3
Daewoo	All models	1999 to 2001	6
Dacia	All models	2005 on	7
Dodge	Avanger, Caliber, Ram	2001 on	3
Daihatsu	All Models	All Years	4
Fiat	Barchetta, Bravo, Brava, Cinquecento, Croma, Doblo, Marea, Panda, Punto	upto 2004	7
Fiat	Tempra, Tipo, Uno, Ducato,	upto 2004	7
Fiat	Panda, Scudo, Croma, Siena, 500, Stilo	2004 on	22
Ford	Fiesta II/III/IV/V, Focus, Mondeo, Transit	up to 2000	12, 14
Ford	Fiesta, Fussion, Focus, KA	2002 to 2007	6
Ford	B-Max, C-Max, Fiesta VI, Focus, Galaxy, Mondeo V, Kuga	2007 on	15
Ford	Transit Connect, Transit Courier, Transit Custom, Transit	2006 on	15